

## Single-Phase Multifunction Meter



### Overview

The PMC-220-A6 Single-Phase Multifunction Meter is CET's latest offer for the low voltage energy metering market featuring DIN-Rail mount, compact construction, high accuracy, multifunction true RMS measurements and a large, easy to read LCD display. The PMC-220-A6 complies with the IEC 62053-21: 2020 & AS 62053.21: 2023 Class 1 and EN 50470-3: 2022 Class B. The PMC-220-A6 comes standard with an LED and a Solid State Pulse Output for energy pulsing. The advanced version of PMC-220-A6 provides 16MB on-board non-volatile memory for Data Recording and an optional Digital Input for status monitoring and pulse counting for collecting WAGES (Water, Air, Gas, Electric and Steam) information. With the standard RS-485 port and Modbus RTU protocol, the PMC-220-A6 becomes a vital component of an intelligent, multifunction monitoring solution for any Power and Energy Management Systems.

### Application

- DIN-Rail mount energy metering
- Industrial, Commercial and Utility Substation Metering
- Building, Factory and Process Automation
- Sub-metering and Cost Allocation
- NMI and MID compliant Energy Management

### Features Summary

#### Ease of Use

- Large, Backlit, 7-Segment LCD for both Data viewing and Configuration
- Two LED indicators for Energy Pulsing and Communication activities
- Easy installation with DIN-Rail mounting, no tools required
- Direct Connected Input up to 80A without external CT
- Password protected setup via Front Panel or free software

#### Basic Measurements

- Multifunction true RMS measurements
  - Voltage (U), Current (I), P, Q, S, PF and Frequency
  - kWh and kvarh Imp./Exp./Tot./Net. and kVAh
  - Device Operating Time (Running Hour)
  - Front Panel & Communication Programming Counters
- Demands and Max. Demands for U, I, P/Q/S and Temperature with timestamp for This Month & Last Month (or Since Last Reset & Before Last Reset)
- 12 Monthly recording of kWh/kvarh Imp./Exp., kVAh as well as kWh Imp./Exp. per Tariff
- Temperature

#### Multi-Tariff TOU

- Two TOU schedules, each providing
  - 12 Seasons
  - 12 Daily Profiles, each with 14 Periods
  - 20 Holidays or Alternate Days
  - 5 Tariffs, each providing kWh/kvarh Imp./Exp. and kVAh

#### Setpoint

- 10 user-programmable Setpoints with extensive list of monitoring parameters including Voltage (U), Current (I), Frequency, P/Q/S/PF Total, P Demand, Temperature and DI Status
- Configurable thresholds and time delay

#### Overcurrent Alarm

- Configurable threshold @ 0.1-100 A and time delay @ 1-99 s
- Alarm Events are stored in SOE Log

#### SOE Log

- 128 events time-stamped to  $\pm 1$ ms resolution
- Setup changes, Setpoint, DI status changes and Overcurrent Alarm, etc.

#### Data Recorder (Advanced Version Only)

- Two Data Recorder Logs of Max. 16 parameters
- Recording Interval from 1 second to 40 days
- Configurable Recording Depth (Max. 65535) and Recording offset
- Capable of recording 16 parameters at 5-min interval for over 7 months
- Available parameters: U, I, P, Q, S, PF, Freq., kWh Imp./Exp., kvarh Imp./Exp., kVAh, Demands and Max. Demands for U, I, P/Q/S Total, DI Pulse Counter, Temperature, and Demand for Temperature

#### Freeze Logs

- 12 Daily Freeze Logs for Total kWh Imp. and kWh Imp. Per Tariff
- 12 Monthly Freeze Logs for Total kWh Imp. and kWh Imp. Per Tariff

#### Tamper Detection and Alarm (Advanced Version Only)

- DI connected to external switch as Setpoint Parameter for Tamper Alarm
- Built-in sensor for Strong Magnetic Tamper Detection
- Alarm Events are stored in SOE Log

#### Communications

- Optically isolated RS-485 port, baud rate from 1,200 to 38,400 bps
- Modbus RTU protocol

#### Security

- Programmable Password protection for configurations on Front Panel
- 3-level independent security Comm. password protection and different access permissions

#### Pulse Outputs

- 1 LED Pulse Output on the Front Panel and 1 Solid State Pulse Output for energy pulsing application

#### Digital Input (Advanced Version Only)

- Optional 1 channel for external status monitoring or pulse counting
- Self-excited, internally wetted

#### Real-Time Clock (Advanced Version Only)

- Battery backed RTC @ 6ppm ( $\leq 0.5$ s/day)

#### System Integration

- Supported by our PecStar® iEMS
- Easy integration into other Automation or SCADA systems via Modbus RTU protocol

### Appearance and Terminals

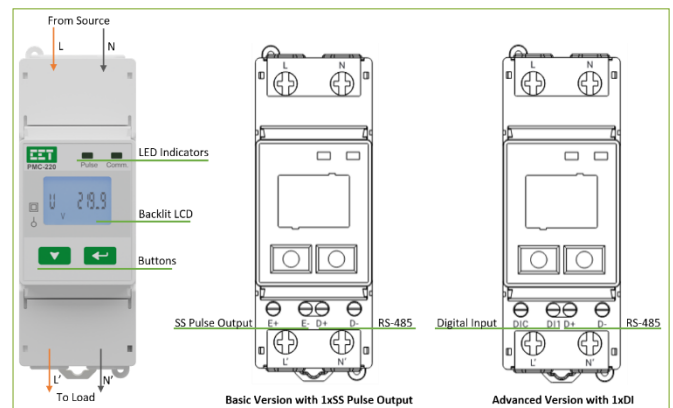

### Dimensions and Installation

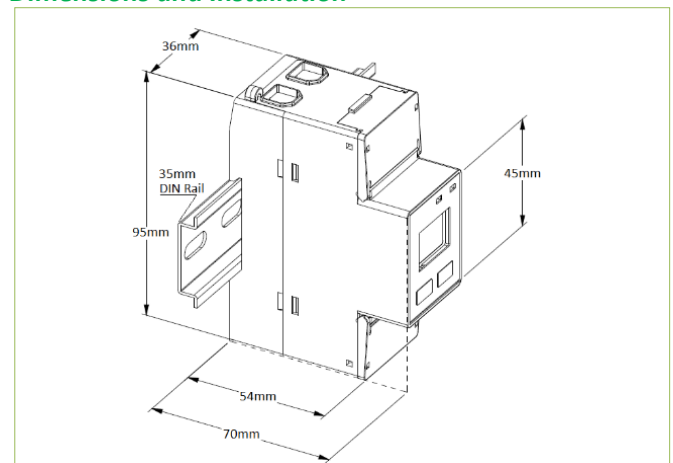

**Designed For Reliability**

**Manufactured To Last**

Accuracy

Parameters	Accuracy	Resolution
Voltage	±0.5%	0.1V
Current	±0.5%	0.001A
P, Q, S	±1.0%	0.01kX
kWh	IEC 62053-21: 2020 & AS 62053.21: 2023 Class 1, EN 50470-3 Class B	0.01kWh
kvarh	IEC 62053-24: 2020 Class 1	0.01kvarh
PF	±1.0%	0.001
Frequency	±0.02Hz	0.001Hz

Technical Specifications

Measurement Inputs (L, N, L', N')	
Voltage (Un)	100VAC 220VAC 230VAC 240VAC
Overrange (% Un)	276% 120% 125% 115%
Range (V)	
Basic Version	120-240V AC, ±15%
Advanced Version	100-240V AC, ±15%
Current (In/Imax)	5A/80A, Direct Connected Input
Starting Current (Ist)	0.4% In (0.02A)
Minimum Current (Imin)	5% In (0.25A)
Burden	<0.1VA
Frequency	45Hz-65Hz
Solid State Energy Pulse Output (Selectable - kWh/kvarh)	
Type	Optically Isolated Solid State Relay
Max. Load Voltage	80 VDC
Max. Forward Current	50 mA (Operating Current: 3.3mA to 10mA)
Pulse Constant	10/100/1000/2000/3200 imp/kXh
Pulse Width	30-500 ms
Communications	
RS-485	Modbus RTU
Baud Rate	1.2/2.4/4.8/9.6/19.2/38.4 kbps
Wire Size	0.2 - 2.0 mm <sup>2</sup> (26 - 14 AWG)
Tightening Torque	2.7 kgf.cm/M3/2.39 lb-in/0.27 N.m
Maximum Torque	5.1 kgf.cm/M3/4.42 lb-in/0.5 N.m
Environmental Conditions	
Operating Temp.	-25°C to +70°C
Storage Temp.	-40°C to +85°C
Humidity	5% to 95% non-condensing
Atmospheric Pressure	70kPa to 106kPa
Pollution Degree	2
Mechanical Characteristics	
Unit Dimensions	36x95x70mm
Mounting	DIN-Rail Mounting
IP Rating	IP51 (Front), IP30 (Body)

Ordering Information

Product Code	Description
PMC-220 Digital Single-Phase Energy Meter	
<b>Basic Function</b>	Multifunction measurements, Bi-directional Energy, Demands and Max. Demands, Monthly Energy Log, Setpoint, SOE Log, Multi-Tariff TOU, Daily & Monthly Freeze Log
<b>Enhanced Features</b>	
A**	Advanced Version (MID, NMI and CE Certified)
B*	Basic Version (CE Certified)
<b>Input Current</b>	
A	5A (80A Max.), Direct Connected Input
<b>Input Voltage</b>	
3	100-240V AC, ±15% (Advanced Version) 120-240V AC, ±15% (Basic Version)
<b>System Frequency</b>	
5	45-65Hz
<b>I/O</b>	
A	1xSS Pulse Output
B	1xDI
<b>Communications</b>	
A	1xRS-485 Port
<b>Protocol</b>	
M	Modbus
<b>Display Language</b>	
E	English
PMC-220 - A6 B A 3 5 A A M E	PMC-220-A6BA35AAME (Standard Model)

\* Additional charges apply  
 \*\* Device with Enhanced Features Option "A" supports additional functions including 16 MB on-board memory, Battery-Backed Real-Time Clock, Data Recorder Log, and Strong Magnetic Tamper Detection, which are not supported on Option "B".  
 \* Device with Enhanced Features Option "B" can only work with I/O option "A".

Standards of Compliance

Safety Requirements	
CE LVD 2014/35/EU	EN 61010-1: 2010 + A1: 2019 EN 61010-2-030: 2021 + A11: 2021
Electrical Safety in Low Voltage Distribution Systems up to 1000Vac and 1500 Vdc	IEC 61557-12: 2021 (PMD)
Products Safety Requirements and Tests	IEC 62052-31: 2015 EN 62052-31: 2016 AS 62052.31: 2017 + A1: 2021 M13-1 4kV @ 1 minute 6kV, 1.2/50µs
Electromagnetic Compatibility	
EMC 2014/30/EU (EN IEC 61326-1: 2021, EN IEC 61326-2-3: 2021)	
Immunity Tests	
Electrostatic Discharge	EN 61000-4-2: 2009
Radiated Fields	EN IEC 61000-4-3: 2020
Fast Transients	EN 61000-4-4: 2012
Surges	EN 61000-4-5: 2014 + A1: 2017
Conducted Disturbances	EN 61000-4-6: 2014
Magnetic Fields	EN 61000-4-8: 2010
Voltage Dips & Interruptions	EN IEC 61000-4-11: 2020
Ring Wave	EN 61000-4-12: 2017
Immunity Standard for Industrial Environments	EN IEC 61000-6-2: 2019
Emission Tests	
Limits and Methods of Measurement of Electromagnetic Disturbance Characteristics of Industrial, Scientific and Medical (ISM) Radio-Frequency Equipment	EN 55011: 2016 + A1: 2017+A11: 2020 + A2: 2021
Electromagnetic Compatibility of Multimedia Equipment - Emission Requirements	EN 55032: 2015 + A11: 2020 + A1: 2020
Limits for Harmonic Current Emissions for Equipment with Rated Current ≤16 A	EN IEC 61000-3-2: 2019 + A1: 2021
Limitation of Voltage Fluctuations and Flicker in Low-Voltage Supply Systems for Equipment with Rated Current ≤16 A	EN 61000-3-3: 2013 + A1: 2019 + A2: 2021
Emission Standard for Industrial Environments	EN IEC 61000-6-4: 2019
Mechanical Tests	
Spring Hammer Test	IEC 62052-31: 2015 & EN 62052-31: 2016 & AS 62052.31: 2017 + A1: 2021
Vibration Test	IEC 62052-11: 2020 & EN IEC 62052-11: 2021 + A11
Shock Test	& AS 62052.11: 2023
Revenue Metering Approval	
NMI M13-1 of Australia	Approval Mark: NMI XX/X/XXX
MID Directive 2014/32/EU	Cert. No.: M4 69268468 0001

CET Electric Technology Inc.

E: [sales@cet-global.com](mailto:sales@cet-global.com)  
 W: [www.cet-global.com](http://www.cet-global.com)

Your Local Representative

Revision Date: April 3, 2026